

QUARTECH CS6V-225M

Canadian Solar's new Quartech modules have significantly raised the standard of module efficiency in the solar industry. They introduced innovative four busbar cell technology, which demonstrates higher power output and higher system reliability. Worldwide, our customers have embraced this next generation of modules for their excellent performance, superior reliability and enhanced value.

NEW TECHNOLOGY

- Reduces cell series resistance
- Reduces stress between cell interconnectors
- Improves module conversion efficiency
- Improves product reliability

KEY FEATURES



Higher energy yield

- Outstanding performance at low irradiance
- Maximum energy yield at low NOCT
- Improved energy production through reduced cell series resistance



Increased system reliability

- Long-term system reliability with IP67 junction box
- Enhanced system reliability in extreme temperature environment with special cell level stress release technology



Extra value to customers

- Positive power tolerance up to 5 W
- Stronger 40 mm robust frame to hold snow load up to 5400 Pa and wind load up to 2400 Pa
- Anti-glare project evaluation
- Salt mist, and ammonia resistance, apply to seaside, and farm environments



insurance-backed warranty
non-cancelable, immediate warranty insurance
linear power output warranty



product warranty on materials
and workmanship

MANAGEMENT SYSTEM CERTIFICATES*

ISO 9001: 2008 / Quality management system

ISO/TS 16949: 2009 / The automotive industry quality management system

ISO 14001: 2004 / Standards for environmental management system

OHSAS 18001: 2007 / International standards for occupational health & safety

PRODUCT CERTIFICATES*

IEC 61215 / IEC 61730: VDE / CE / JET / MCS

IEC 61701 ED2: VDE / IEC 62716: VDE / PV CYCLE (EU)



*As there are different certification requirements in different markets, please contact your local Canadian Solar sales representative for the specific certificates applicable to the products in the region in which the products are to be used.

CANADIAN SOLAR INC. is committed to providing high quality solar products, solar system solutions and services to customers around the world. As a leading manufacturer of solar modules and PV project developer with about 10 GW of premium quality modules deployed around the world since 2001, Canadian Solar Inc. (NASDAQ: CSIQ) is one of the most bankable solar companies worldwide.

CANADIAN SOLAR INC.

545 Speedvale Avenue West, Guelph, Ontario N1K 1E6, Canada, www.canadiansolar.com, support@canadiansolar.com

MODULE / ENGINEERING DRAWING (mm)

Rear View

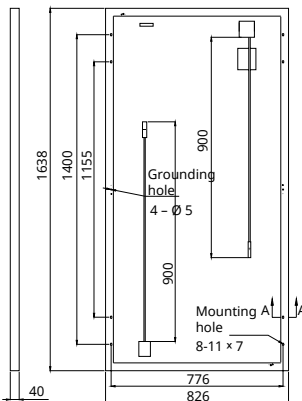

Frame Cross Section A-A

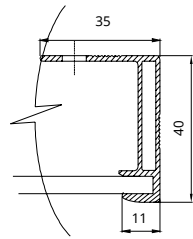

Mounting Hole

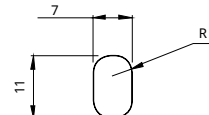

CS6V-225M / I-V CURVES

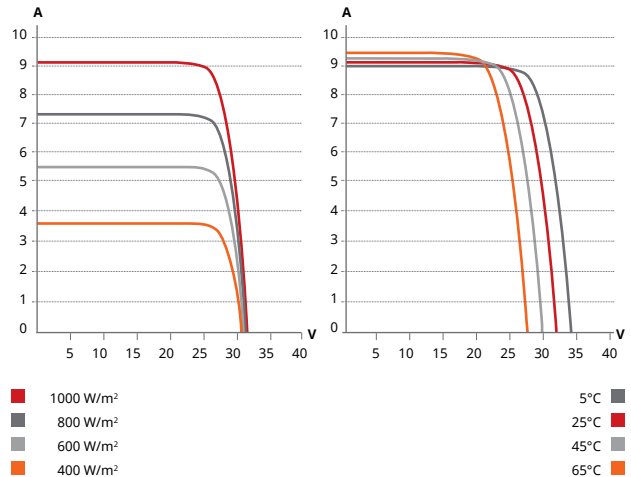

ELECTRICAL DATA / STC*

Electrical Data CS6V	225M
Nominal Max. Power (Pmax)	225 W
Opt. Operating Voltage (Vmp)	26.0 V
Opt. Operating Current (Imp)	8.67 A
Open Circuit Voltage (Voc)	31.8 V
Short Circuit Current (Isc)	9.19 A
Module Efficiency	16.63%
Operating Temperature	-40°C ~ +85°C
Max. System Voltage	1000 V (IEC)
Max. Series Fuse Rating	15 A
Application Classification	Class A
Power Tolerance	0 ~ + 5 W

* Under Standard Test Conditions (STC) of irradiance of 1000 W/m², spectrum AM 1.5 and cell temperature of 25°C.

ELECTRICAL DATA / NOCT*

Electrical Data CS6V	225M
Nominal Max. Power (Pmax)	162 W
Opt. Operating Voltage (Vmp)	23.7 V
Opt. Operating Current (Imp)	6.85 A
Open Circuit Voltage (Voc)	29.2 V
Short Circuit Current (Isc)	7.44 A

* Under Nominal Operating Cell Temperature (NOCT), irradiance of 800 W/m², spectrum AM 1.5, ambient temperature 20°C, wind speed 1 m/s.

PERFORMANCE AT LOW IRRADIANCE

Industry leading performance at low irradiation, average 96.5% relative efficiency from an irradiance of 1000 W/m² to 200 W/m² (AM 1.5, 25°C).

The specification and key features described in this datasheet may deviate slightly and are not guaranteed. Due to on-going innovation, research and product enhancement, Canadian Solar Inc. reserves the right to make any adjustment to the information described herein at any time without notice. Please always obtain the most recent version of the datasheet which shall be duly incorporated into the binding contract made by the parties governing all transactions related to the purchase and sale of the products described herein.

Caution: For professional use only. The installation and handling of PV modules requires professional skills and should only be performed by qualified professionals. Please read the safety and installation instructions before using the modules.

MODULE / MECHANICAL DATA

Specification	Data
Cell Type	Mono-crystalline, 6 inch
Cell Arrangement	50 (5×10)
Dimensions	1638×826×40 mm (64.5×32.5×1.57 in)
Weight	16.0 kg (35.3 lbs)
Front Cover	3.2 mm tempered glass
Frame Material	Anodized aluminium alloy
J-Box	IP67, 3 diodes
Cable	4 mm ² (IEC), 900 mm (35.4 in)
Connectors	Friends PV2a (IEC), Friends PV2b (IEC / UL)
Standard Packaging	38 pieces, 685 kg (1510.2 lbs) (quantity & weight per pallet)
Module Pieces per Container	532 pieces

TEMPERATURE CHARACTERISTICS

Specification	Data
Temperature Coefficient (Pmax)	-0.41% / °C
Temperature Coefficient (Voc)	-0.31% / °C
Temperature Coefficient (Isc)	0.053% / °C
Nominal Operating Cell Temperature	45±2°C

PARTNER SECTION

